

Duplex II Reference

Disassemble Pump Housing

1. Disconnect power to the pump motor. Relieve system pressure. Disconnect inlet and outlet hoses.
2. Remove pressure switch cover and remove wire leads from switch assembly.
3. Remove the four recessed pump housing screws located on top of the pump housing.
4. Remove the pump housing from diaphragm/lower housing assembly.

Check Valve Assembly: Follow steps 1 through 4

5. The check valve housing and o-ring located in the upper housing or on the diaphragm cam assembly.
6. If in the upper housing, remove by placing a small flat bladed screwdriver between the upper housing and check valve and pry out.

Diaphragm / Cam Assembly

7. Remove two deep set Phillips headed screws.
8. Rotate bearing cover, so access notch is aligned with cam bearing set screw, loosen set screw with 1/8" allen wrench and slide pump lower housing assembly from motor shaft.
9. After removing the cam bearing from the outer piston set, the inner piston screws are now visible, remove both flat headed screws. The outer piston set can now be removed from the two inner pistons.

Reassemble Diaphragm / Cam Assembly

1. Place hex stem of inner pistons through the diaphragm and the openings in the lower housing and into outer piston set.
2. Center pistons in the diaphragm and install two flat headed screws.
3. Place cam bearing over outer piston set aligning locating pins into the holes of the cam bearing housing.
4. Install round headed screws and tighten securely.

Lower Housing

5. Coat motor shaft with grease prior to installing the diaphragm/cam bearing assembly to motor.
6. Attach cam bearing assembly to motor shaft by aligning shaft indentation with set screw and tighten securely (Rotate access notches down toward the base plate)
7. Install and tighten 2 phillips headed screws to motor (torque to 25 inch pounds [2.8 Nm]).

Check Valve Assembly

8. Install check valve with new o-ring over the pistons in diaphragm, discharge side up (side with center circle up).

Pump Housing

9. Place pump housing over check valve and align the four screw holes with lower housing.
10. Install the four Phillips headed screws into the bearing cover and cross tighten.

NOTE: Pressure switches listed are NPT. For direct mount please change the "5" in part number to "0"
(ie. 02095100 becomes 02095100)

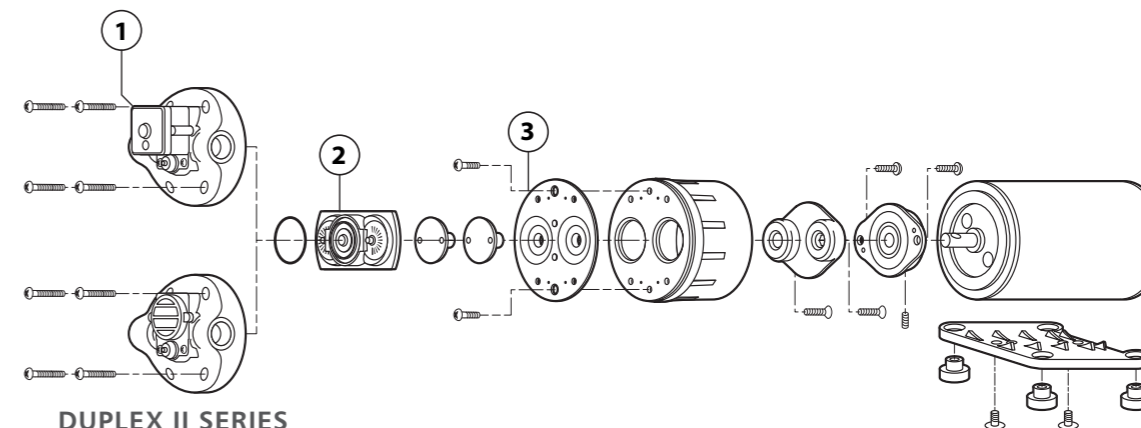

DUPLEX II SERIES

PART NO.	PRESSURE SWITCH	CHECK VALVE	DIAPHRAGM
D12X000R	NA	20914003A	21010004
D1722F5011RL	02095100	20914002A	21010004
D1725E6011RL	02090121	20914003A	21010003
D1725F1411RL	NA	20914002A	21010004
D1725H1411RL	NA	20914003A	21010004
D1725H1412RL	NA	20914003A	21010004
D1725J6011RL	02090121	20914002A	21010003
D1732F1311RL	NA	20914002A	21010004
D1732F5011RL	02095100	20914002A	21010004
D1732F5011RL	02095100	20914002A	21010004
D1732H1311RL	NA	20914003A	21010004
D1732H5011RL	02095100	20914003A	21010004
D1735E7011RL	02090120	20914003A	21010003
D1735H7011RL	02090120	20914003A	21010004
D1735J7011RL	02090120	20914002A	21010003
D17X001RL	NA	20914003A	21010004
D17X002RL	NA	20914003A	21010004
D17X002RL	NA	20914003A	21010004
D2121F5011R	02095100	20914002A	21010004
D2122F1212R	NA	20914002A	21010004
D2124F1411R	NA	20914002A	21010004
D2125F6011R	02090121	20914002A	21010004
D2131F1311R	NA	20914002A	21010004
D2132F5011R	02095100	20914002A	21010004
D2132F6011R	02090121	20914002A	21010004
D2134F1411R	NA	20914002A	21010004
D2134F6011R	02090121	20914002A	21010004
D2135J7011R	02090120	20914002A	21010003
D31211211R	NA	20914001A	21010002
D31213011R	02095109	20914001A	21010002
D3121E1211R	NA	20914003A	21010003
D3121E3011R	02095109	20914003A	21010003
D3121F1211R	NA	20914003A	21010004
D3121H1211R	NA	20914003A	21010004

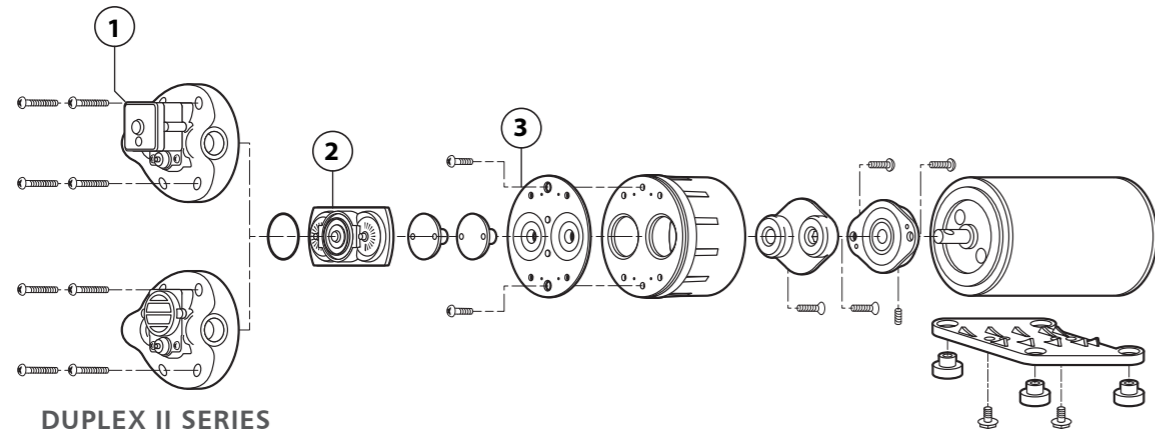

DUPLEX II SERIES

PART NO.	PRESSURE SWITCH	CHECK VALVE	DIAPHRAGM
D3121H3011R	02095109	20914003A	21010004
D3121V1211R	NA	20914002A	21010001
D3121V3011R	02095109	20914002A	21010001
D31311311R	NA	20914001A	21010002
D31311312R	NA	20914001A	21010002
D31315011R	02095100	20914001A	21010002
D3131E1311R	NA	20914003A	21010003
D3131E5011R	02095100	20914003A	21010003
D3131F1311R	NA	20914002A	21010004
D3131H1111R	NA	20914003A	21010004
D3131H1311R	NA	20914003A	21010004
D3131H5011R	02095100	20914003A	21010004
D3131H5012R	02095100	20914003A	21010004
D3131V1311R	NA	20914002A	21010001
D3131V5011R	02095100	20914002A	21010001
D3131V6011R	02095100	20914002A	21010001
D31341311R	NA	20914001A	21010002
D31345011R	02095100	20914001A	21010002
D3134H1311R	NA	20914003A	21010004
D31351311R	NA	20914001A	21010002
D31351412R	NA	20914001A	21010002
D31357011R	02090120	20914001A	21010002
D3135E1411R	NA	20914003A	21010003
D3135E7011R	02090120	20914003A	21010003
D3135F1411R	NA	20914002A	21010004
D3135H1411R	NA	20914003A	21010004
D3135H7011R	02090120	20914003A	21010004
D3135V1411R	NA	20914002A	21010001
D3145H5011R	02095100	20914003A	21010004
D31X020R	NA	20914002A	21010001
D31X023R	NA	20914001A	21010002
D31X024R	02095103	20914004A	21010003
D31X026R	NA	20914002A	21010004
D31X033R	NA	20914003A	21010003

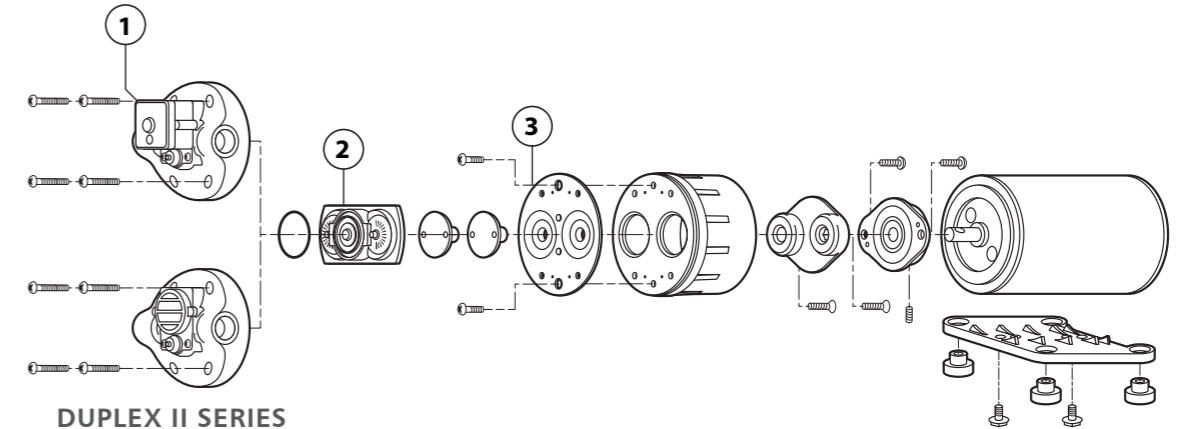

DUPLEX II SERIES

PART NO.	PRESSURE SWITCH	CHECK VALVE	DIAPHRAGM
D31X033R	NA	20914003A	21010003
D32211211R	NA	20914001A	21010002
D32213011R	02095109	20914001A	21010002
D3221E1212R	NA	20914003A	21010003
D3221E3011R	02095109	20914003A	21010003
D3221H1212R	NA	20914003A	21010004
D3221H3011R	02095109	20914003A	21010004
D3221H5011R	02095100	20914003A	21010004
D3221V1211R	NA	20914002A	21010001
D3221V3011R	02095109	20914002A	21010001
D3224H4012R	02095103	20914003A	21010004
D32311311R	NA	20914001A	21010002
D32315011R	02095100	20914001A	21010002
D3231E1211R	NA	20914003A	21010003
D3231E5011R	02095100	20914003A	21010003
D3231H1311R	NA	20914003A	21010004
D3231H5011R	02095100	20914003A	21010004
D3231V1311R	NA	20914002A	21010001
D3231V5011R	02095100	20914002A	21010001
D3234H1111R	NA	20914003A	21010004
D32357011R	02090120	20914001A	21010002
D3235E1411R	NA	20914003A	21010003
D3235E5011R	02095100	20914003A	21010003
D3235E7011R	02090120	20914003A	21010003
D3235H1411R	NA	20914003A	21010004
D3235H7011R	02090120	20914003A	21010004
D3235J7011R	02090120	20914002A	21010003
D32X002R	02095103	20914003A	21010004
D32X003R	NA	20914003A	21010004
D32X004R	02095100	20914001A	21010002
D32X005R	NA	20914003A	21010003
D36211311R	NA	20914001A	21010002
D3621H1212R	NA	20914003A	21010004
D3631H1311R	NA	20914003A	21010004

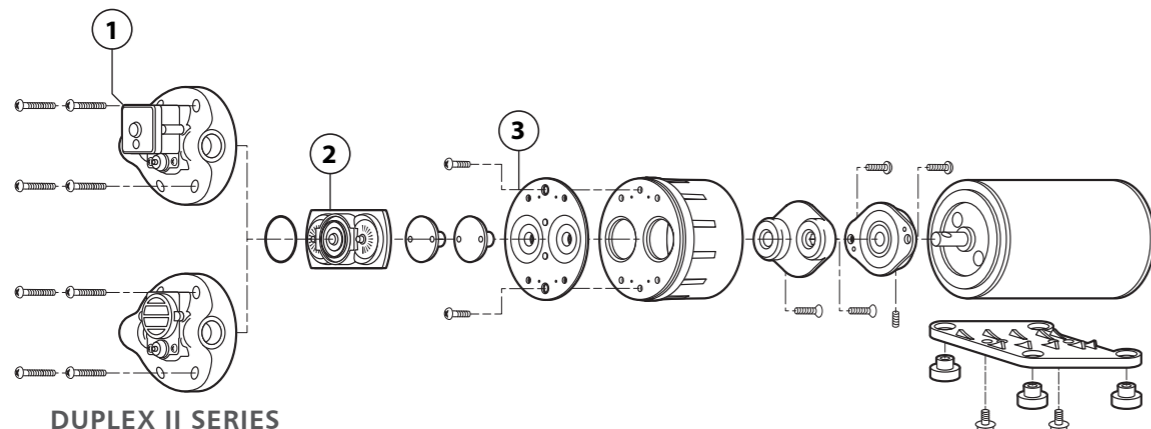

DUPLEX II SERIES

PART NO.	PRESSURE SWITCH	CHECK VALVE	DIAPHRAGM
D3631H1312R	NA	20914003A	21010004
D3631H5011R	02095100	20914003A	21010004
D3631V1311R	NA	20914002A	21010001
D37125011RL	02095100	20914001A	21010002
D3712H1311RL	NA	20914003A	21010004
D3712H1312RL	NA	20914003A	21010004
D37221211RL	NA	20914001A	21010002
D37223011RL	02095109	20914001A	21010002
D3722E1211RL	NA	20914003A	21010003
D3722E3011RL	02095109	20914003A	21010003
D3722H1211RL	NA	20914003A	21010004
D3722H1311RL	NA	20914003A	21010004
D3722H1312RL	NA	20914003A	21010004
D3722H3011RL	02095109	20914003A	21010004
D3722V1211RL	NA	20914002A	21010001
D3722V3011RL	02095109	20914002A	21010001
D3725V1411RL	NA	20914002A	21010001
D37321311RL	NA	20914001A	21010002
D37325011RL	02095100	20914001A	21010002
D3732E1311RL	NA	20914003A	21010003
D3732E4011RL	02095103	20914003A	21010003
D3732E5011RL	02095100	20914003A	21010003
D3732F1311RL	NA	20914002A	21010004
D3732H1311RL	NA	20914003A	21010004
D3732H1312R	NA	20914003A	21010004
D3732H5011RL	02095100	20914003A	21010004
D3732V1311RL	NA	20914002A	21010001
D3732V3011RL	02095109	20914002A	21010001
D3732V5011RL	02095100	20914002A	21010001
D37351411RL	NA	20914001A	21010002
D37357011RL	02090120	20914001A	21010002
D3735E1411RL	NA	20914003A	21010003
D3735E7011RL	02090120	20914003A	21010003
D3735H1411RL	NA	20914003A	21010004

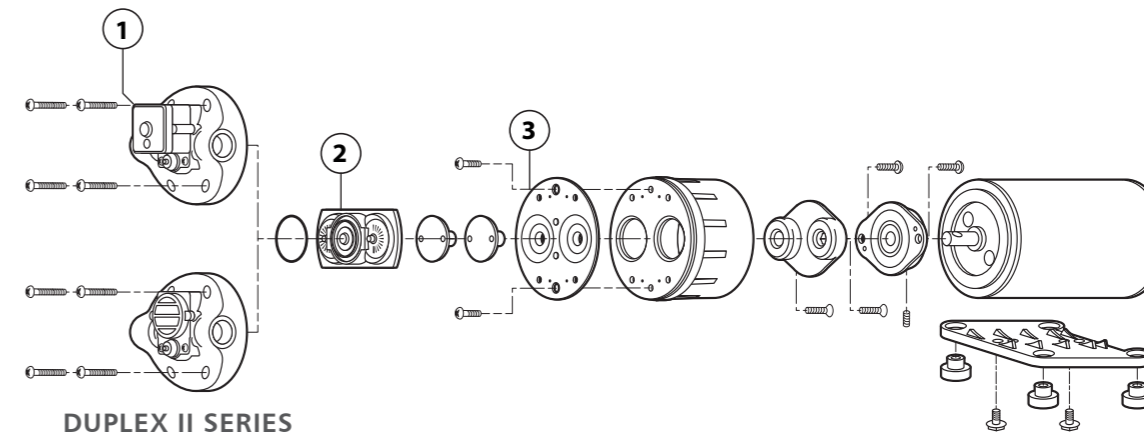

DUPLEX II SERIES

PART NO.	PRESSURE SWITCH	CHECK VALVE	DIAPHRAGM
D3735H1512RL	NA	20914003A	21010004
D3735H7011RL	02090120	20914003A	21010004
D3735V1411RL	NA	20914002A	21010001
D3742H5011RL	02095100	20914003A	21010004
D37X000R	NA	20914003A	21010003
D37X006R	02095100	20914003A	21010004
D37X008R	NA	20914003A	21010003
D37X011RL	NA	20914002A	21010004
D37X012RL	02095115	20914003A	21010003
D37X013R	02095109	20914002A	21010001
D4722H4011R	02095103	20914003A	21010004
D4922H4011R	02095103	20914003A	21010004
D4932H5011R	02095100	20914003A	21010004
D4935H5011R	02095100	20914003A	21010004
D4935H6011R	02090121	20914003A	21010004
D4935H7011R	02090120	20914003A	21010004
D7125G1411R	NA	20914001A	21010004
D7125G6011R	02090121	20914001A	21010004
D7131G1311R	NA	20914001A	21010004
D7131G5011R	02095100	20914001A	21010004
D7135I7011R	02090120	20914002A	21010002
D71X000R	NA	20914001A	21010002
D71X002R	NA	20914001A	21010002
D71X004R	NA	20914003A	21010004
D71X005R	NA	20914001A	21010002
D7225G1411R	NA	20914001A	21010004
D72315011R	02095100	20914001A	21010002
D72X001R	02090120	20914001A	21010002
D72X003R	NA	20914002A	21010001

Troubleshooting for all products:

Pulsating Flow – Pump cycles on and off:

- Restricted pump delivery.
- Check discharge lines, fittings and valves for undersizing or clogging

Failure to Prime – Motor operates but no pump discharge

- Restricted intake or discharge line
- Air leak in intake line
- Punctured pump diaphragm
- Debris under flapper valves
- Crack in pump housing

Motor fails to turn on

- Loose wiring connection
- Pump circuit has no power
- Blown fuse / thermal protector tripped
- Pressure switch failure
- Defective motor

Pump fails to turn off after all valves are closed

- Empty tank
- Punctured pump diaphragm
- Discharge line leak
- Defective pressure switch
- Insufficient voltage to pump
- Debris under flapper valves

Low flow and pressure

- Air leak at pump intake
- Accumulation of debris inside pump and plumbing
- Worn pump bearing (excessive noise)
- Punctured pump diaphragm
- Defective motor

Pumps have thermal overload protected motors. The motor will automatically shut off if temperature rises due to an overload condition. If the motor shuts off in this manner, turn electrical power off and close all nozzles or valves. After a cooling off period the pump will automatically re-start.

Product Warranty:

ITT Flojet warrants products to be free of defects in material and/or workmanship for a period of one year after purchase by the customer from Flojet. During this one year warranty period, Flojet will at its option, at no charge to the customer, repair or replace this product if found defective, with a new or reconditioned product, but not to include costs of removal or installation. No product will be accepted without a return authorization number and COSSH sheet completed. All returned goods must be shipped with transportation charges prepaid. This is only a summary of our Limited Warranty. For a copy of our complete warranty, please request form no F100-101.