



## P.A. - S.p.A. - EQUIPAGGIAMENTI TECNICI DEL LAVAGGIO

VIA MILANO, 13 - CASELLA POSTALE 115 - 42048 RUBIERA (REGGIO EMILIA) - ITALY  
Tel. +39 0522 623611 - Fax. +39 0522 629600 - R.E.A. RE 156319 - R. I. RE 11535 - Mecc. RE 013446  
C.F. e P. IVA 01035950359 - Cap. Soc. i.v. € 750.000,00 - Codice Identificativo C.E.E. IT 01035950359  
ART. 2497 - BIS C.C. DIREZIONE E COORDINAMENTO BENETTI srl R.I. TRIB. DI RE 01480690351  
<http://www.pa-etl.it> - E-mail: [info@pa-etl.it](mailto:info@pa-etl.it)



## VS160 – VS30 – Compensated safety valve

Technical manual: E 218

Compensated pressure regulating valve.  
Regulates the bypass of the fluid with a minimum variation of the pressure.  
Suitable to be utilized as a safety valve.

DN 8



- **60.0560.00** VS160 G1/4 M
- **60.0560.30** VS30 G1/4 M

- Central body in brass
- Internal components in Sst.
- Moving parts totally protected.
- Discharge through integrated hose barb.
- Secure intervention discharging all the flow.
- Prompt and effective damping against pressure spikes.

### TECHNICAL SPECIFICATIONS

Max. flow rate 14 l/min - Max. temperature 90°C (1)

Part number	Rated pressure	Permissible pressure	Minimum adjustable pressure	(2) Pressure increase as a VS – as a VRP	Inlet	Bypass	Weight
	bar - MPa	bar - MPa	bar - MPa	bar – MPa - bar - MPa			
<b>60.0560.00</b>	140 - 14	160 - 16	14 – 1.4	20 – 2 – 9 – 0.9	G1/4 M	G1/8 F D. 13 mm	135
<b>60.0560.30</b>	30 - 3	35 – 3.5	5 – 0.5	15 – 1.5 – 15 - 1.5	G1/4 M	G1/8 F D. 13 mm	135

(1) The valve has been designed for a continuous use at a water temperature of 60°C. It can resist for short periods at a maximum temperature of 90°C.

(2) **Pressure increase** = is the increase of pressure needed into the valve for discharging the max. flow when utilized at rated pressure

**Instruction manual, maintenance, installation, spare parts.**

For a correct utilization, follow the directions of this manual

**Re-print them on the use and maintenance booklet of the machine.**

n. 12.9218.00

## DIMENSIONAL DRAWING

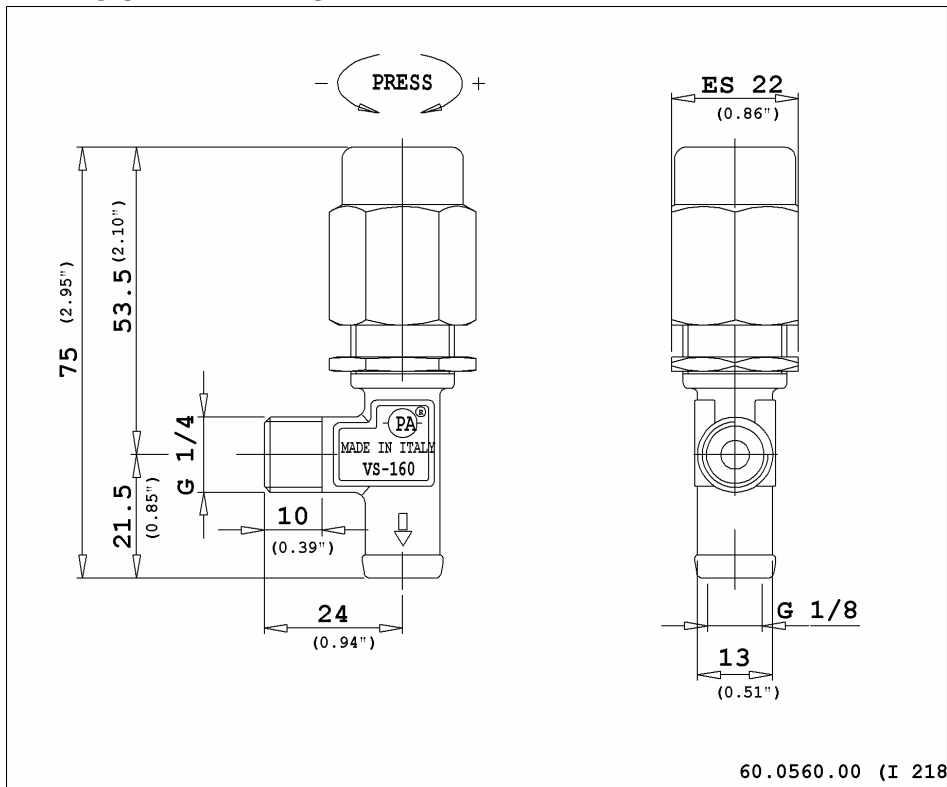

## INSTRUCTIONS

### SELECTION

This product is to be utilized with clean fresh water, even slightly additivated with normal detergents. For use involving different or corrosive liquids, contact the PA Technical department. Choose the valve in line with the data of nominal running (system rated pressure, max flow and max temperature). In any case, the pressure of the machine should not exceed the permissible pressure rate imprinted on the valve. When in use as pressure regulator, adopt a nozzle that allows a bypass of at least 5% of the total flow, bearing in mind that a worn out nozzle causes pressure loss. The valve, assembled in line with these indications, avoids pressure spikes whilst the machine is in operation.

### INSTALLATION

This accessory, on a system that produces hot water, must be fitted **in front of the heat generator**.

Utilize connection fittings in compliance to the dimensions and performance of the valve. Avoid restriction of the passage diameters which can be the cause of malfunctions, pressure reduction and duration.

As a **SAFETY VALVE**: in the case when frequently combined with unloader valves and low pressure in the pump, it has to be fitted in the section that remains pressurized when the gun is shut off.

### OPERATIONS

The valve inlet is on the side, the discharge is opposite the adjustment knob (pos.10). The discharge should be returned to a baffled tank. If, on the contrary, the pump is fed directly from the water mains, it is advisable to install a pressure reducing valve, before the pump, to avoid dangerous pressure spikes which could badly damage manifolds and suction valves. In case of extended conditions of bypass directed to the suction side of the pump, it is recommended to install a thermal valve (VT3 or VT6) to avoid dangerous water temperature build-up.

### PRESSURE ADJUSTMENT/SETTING

As a **SAFETY VALVE**: the adjustment has to be made in such a way that the pressure setting is not superior to the system working pressure and its accessories; this prevents the arisal of numerous pressure increases in hot water systems and static pressure (gun shut off). In order not to exceed the fixed pressure, it is advised to lock the nut (pos 2) against the knob (pos 10) touching them with paint to avoid loosening or tampering.

## PROBLEMS AND SOLUTIONS

PROBLEMS	PROBABLE CAUSES	SOLUTIONS
----------	-----------------	-----------

Valve cycles	- Air inside the system - Worn out seals - Clogged circuit	- Flush out - Replace - Clean or widen passages
The valve does not reach pressure	- Unproper nozzle size - Seat/shutter/ball worn out - Damaged nozzle	- Modify - Replace - Replace
Pressure drop	- Worn out nozzle - Pump gaskets worn out - Valve seat worn out - Air inside the system	- Replace - Replace - Replace - Flush out
Pressure spikes	- There is not a min.5% of total flow in bypass - Clogged nozzle	- Re-adjust - Clean - Repeat adjustment and replace nozzle
Water leakage from bypass	- O-ring seat damaged - Damaged seat	- Replace - Replace

**REGULATIONS :** *see norm manual*

**The accessory hereby described bears the CE marking in accordance with the Norms and Directives applied on the Declaration of conformity.**

For a correct utilization, follow the directions described in this manual and re-print them on the Use and maintenance manual of the machine.

Make sure that you are given **the Original Conformity Declaration** for the accessory chosen. The present manual is valid for all unloader valves named **VS160**.

## MAINTENANCE

Maintenance has to be carried out by **Specialized Technicians**.

**STANDARD:** every 400 working hours (circa 10,000 cycles), check and lubricate the seals with water resistant grease.

**SPECIAL:** every 800 working hours( circa 20,000 cycles), control the wear of the seals and internal parts and if necessary, replace with original PA parts taking care during installation and to lubricate with water resistant grease.

**ATTENTION:** reassemble the valve in the correct manner paying special attention how to set the valve as described in the paragraph **PRESSURE ADJUSTMENT/SETTING**.

**The manufacturer is not to be considered responsible for damage as a result from incorrect fitting and maintenance**

Technical data, descriptions and illustrations are indicative and liable to modification without notice.