



Self-Priming Centrifugal Pumps
& Motor Assemblies
Assembly & Operating Instructions



Unit 8, Hudson Road
Saxby Road Ind. Est.
Melton Mowbray
Leicestershire LE13 1BS

Telephone: +44 (0)1664 567226 Fax: +44 (0)1664 410127
E-mail: info@dualpumps.co.uk www.dualpumps.co.uk

| | |
|---------------------|--|
| Model | |
| Serial No. | |
| Engine No. | |
| Year of Manufacture | |



Appendix 4. A Series Water Pump Service Parts List

| NO. | PART NUMBER | DESCRIPTION | QTY |
|-------------|---------------|--|-------------|
| 1 | 9907-722-30B | PLUG, Filler, Black Polyester | 1 |
| 3 | 9907-765-71 | O-RING, Filler Plug, BUNA-N | 1 |
| | 9907-765-72 | O-RING, Filler Plug, EPDM (standard) | 1 |
| | 9907-765-73 | O-RING, Filler Plug, VITON | 1 |
| 4 | 9907-1262-30B | BRACKET, Black Polyester | 1 |
| 5 | 9907-721 | NUT, Plated Steel, 1/4"-20 | 10 |
| 7 | 907-715-10 | SCREW, 5/16-24 x 1.25" Long, Stainless Steel, for Pumps close-coupled to engines and cast pedestal mounted | 4 |
| 8 | 9907-1245-71 | O-RING, Screw Plug, BUNA-N | 4 |
| | 9907-1245-72 | O-RING, Screw Plug, EPDM (standard) | 4 |
| | 9907-1245-73 | O-RING, Screw Plug, VITON | 4 |
| 9 | 9907-1233-30 | PLUG, Screw, Black Polyester | 4 |
| 10 | 9907-718 | KEY, 3/16" Sq. x 15/16" Long, Steel | 1 |
| 11 | 9907-1302-30 | VOLUTE, Rear, Black Polyester | 1 |
| 12 | 9907-1246-71 | O-RING, Segment, BUNA-N | 1 |
| | 9907-1246-72 | O-RING, Segment, EPDM (standard) | 1 |
| | 9907-1246-73 | O-RING, Segment, VITON | 1 |
| 13 | 9907-683-30 | IMPELLER, Black Polyester | 1 |
| 14 | 9907-717-71 | O-RING, Screw, BUNA-N | 5 |
| | 9907-717-72 | O-RING, Screw, EPDM (standard) | 5 |
| | 9907-717-73 | O-RING, Screw, VITON | 5 |
| 15 | 9907-716-10 | SCREW, Impeller, 5/16-24 x .75" Long, Stainless Steel | 1 |
| 16 | 9907-1348-10 | SCREW, Volute, #10 x .75", Stainless Steel | 7 |
| 17 | 9907-1009-71 | O-RING, Drain Plug, BUNA-N | 1 |
| | 9907-1009-72 | O-RING, Drain Plug, EPDM (standard) | 1 |
| | 9907-1009-73 | O-RING, Drain Plug, VITON | 1 |
| 18 | 9907-723-30 | PLUG, Drain, Black Polyester | 1 |
| 19 | 9907-1261-30B | BODY, 2" NPT, Black Polyester | 1 |
| | 9907-1873-30B | BODY, 2" BSP, Black Polyester | 1 |
| 20 | 9907-720 | SCREW, Body, Plated Steel, 1/4"-20 x 2-3/8" | 10 |
| 21 | 9907-778-11 | SHIM, Impeller, .006", Stainless Steel | as required |
| | 9907-778-12 | SHIM, Impeller, .015", Stainless Steel | as required |
| | 9907-778-13 | SHIM, Impeller, .030", Stainless Steel | as required |
| 22, 25 & 26 | 9907-714-11 | SHAFT SEAL, BUNA-N | 1 |
| | 9907-714-12 | SHAFT SEAL, EPDM (standard) | 1 |
| | 9907-714-14 | SHAFT SEAL, VITON | 1 |
| 23 | 9907-1926-71 | O-RING, Body, BUNA-N | 1 |
| | 9907-1926-72 | O-RING, Body, EPDM (standard) | 1 |
| | 9907-1926-73 | O-RING, Body, VITON | 1 |
| 26 | 9907-976-71 | O-RING, Shaft Seal, BUNA-N | 1 |
| | 9907-976-72 | O-RING, Shaft Seal, EPDM (standard) | 1 |
| | 9907-976-73 | O-RING, Shaft Seal, VITON | 1 |
| 27 | 9907-1872-71 | CHECK VALVE, BUNA-N | 1 |
| | 9907-1872-72 | CHECK VALVE, EPDM (standard) | 1 |
| | 9907-1872-73 | CHECK VALVE, VITON | 1 |
| 28 | 9907-1203-71 | O-RING, Rear Volute, BUNA-N | 1 |
| | 9907-1203-72 | O-RING, Rear Volute, EPDM (standard) | 1 |
| | 9907-1203-73 | O-RING, Rear Volute, VITON | 1 |
| 29 | 9907-1303-30 | VOLUTE, Front, Flat, Black Polyester | 1 |

Dual Pumps Ltd

Self-Priming Centrifugal Pumps & Motor Assemblies Assembly and Operating Instructions

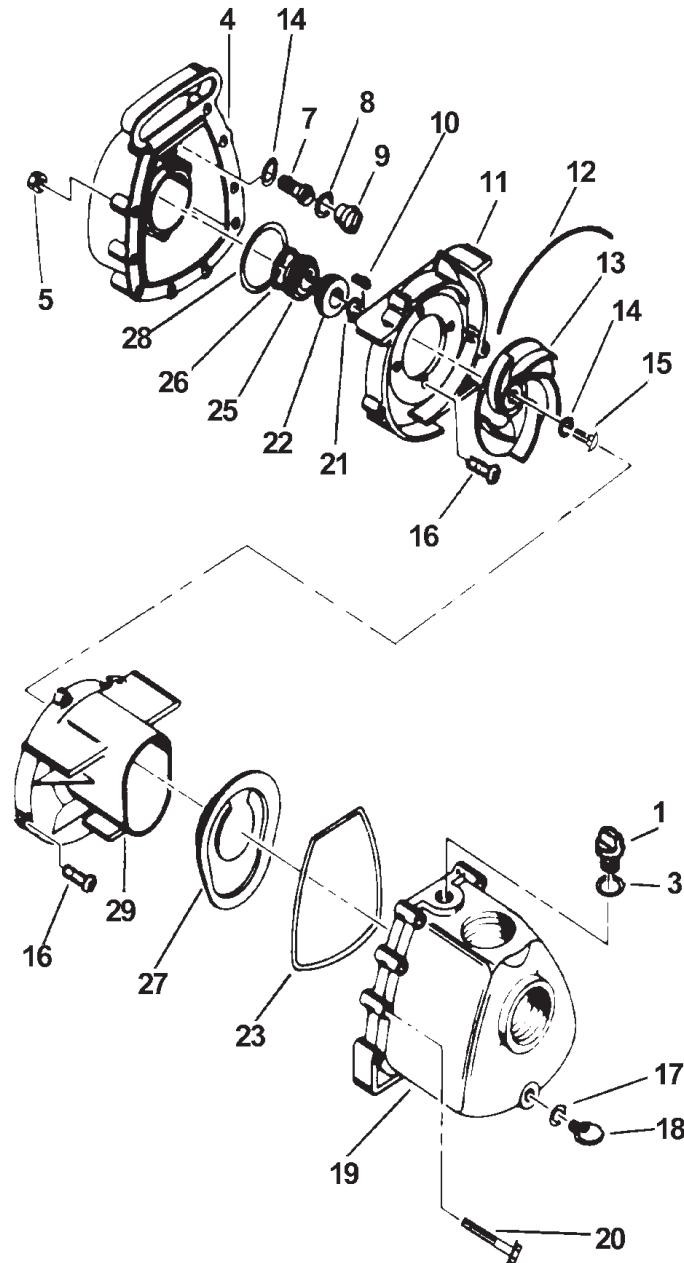

These instructions should be kept with the respective pump unit at all times and referred to as often as necessary.

This manual has been compiled to give all of the necessary information to allow for the safe installation and operation of the Dual Pumps Ltd range of Centrifugal Pumps and Motor Assemblies. Following these simple instructions will ensure operator safety and prolong the life of the equipment.

This manual and any other literature supplied should be read thoroughly before attempting to operate any supplied unit. Pay particular attention to any instructions given relating to your personal safety or to the safety of others who may be in the general area of the operating unit, also specific instructions relating to the starting and stopping of petrol and diesel engines.

Our policy is to improve our product continuously and we therefore reserve the right to change specifications, models or designs without notice or obligation.

EC DECLARATION OF CONFORMITY

Dual Pumps Ltd
 Unit 8, Hudson Road
 Saxby Road Ind. Est.
 Melton Mowbray
 Leicestershire, LE13 1BS

Declares that this equipment conforms to the following directives,
 98/37EC, 73/23 EEC, 2000/14/EC, 2004/108/EEC

Name: S Travis
 Position: Service Manager.



Signature: *S Travis*

(A full certificate of conformity can be obtained upon request).

Appendix 3. Fittings and Accessories

| Illustration Number | Part Description | Part Number, 2 inch pump | Part number, 3 inch pump | Quantity required |
|---------------------|---|-------------------------------|------------------------------|--|
| 1 | Suction hose, Kanaflex Delivery hose, Kanaflex Delivery hose, Layflat | 12-CD20 12-CD20 P3 2LFB | 12-CD30 12-CD30 P48LFB | Per metre Per metre Per metre |
| 2 | Basket foot filter (water pump) | 9907-733-01 | 9907-757-90 | Each |
| 3 | Hose barb | HB 200P (2in NPT) | HB 300P (3in NPT) | Each |
| 4 | Basket foot filter | 9907-46286-00 | 9907-46287-00 | Each |
| 5 | 90 Male adapter | 200F-90 | 9901-SL300-90 | Each |
| 6 | Hose coupler | 200CP | 300CP | Each |
| 7 | Male adapter | 200FP | 300FP | Each |
| 8 | Sponge gasket | 200G | 300G | Each |

1. Index

| | |
|--------------------------------|------------|
| Equipment Variants and Options | Section 2 |
| Safety | Section 3 |
| Description of Main Features | Section 4 |
| Installation | Section 5 |
| Operation | Section 6 |
| Maintenance | Section 7 |
| Fault Finding | Section 8 |
| After use storage | Section 9 |
| Disposal | Section 10 |
| Warranty | Section 11 |

Appendices

| | |
|---|------------|
| Water Pump, service parts list | Appendix 1 |
| Slurry Pump, service parts list | Appendix 2 |
| Fittings and Accessories | Appendix 3 |
| A Series Water Pump, service parts list | Appendix 4 |

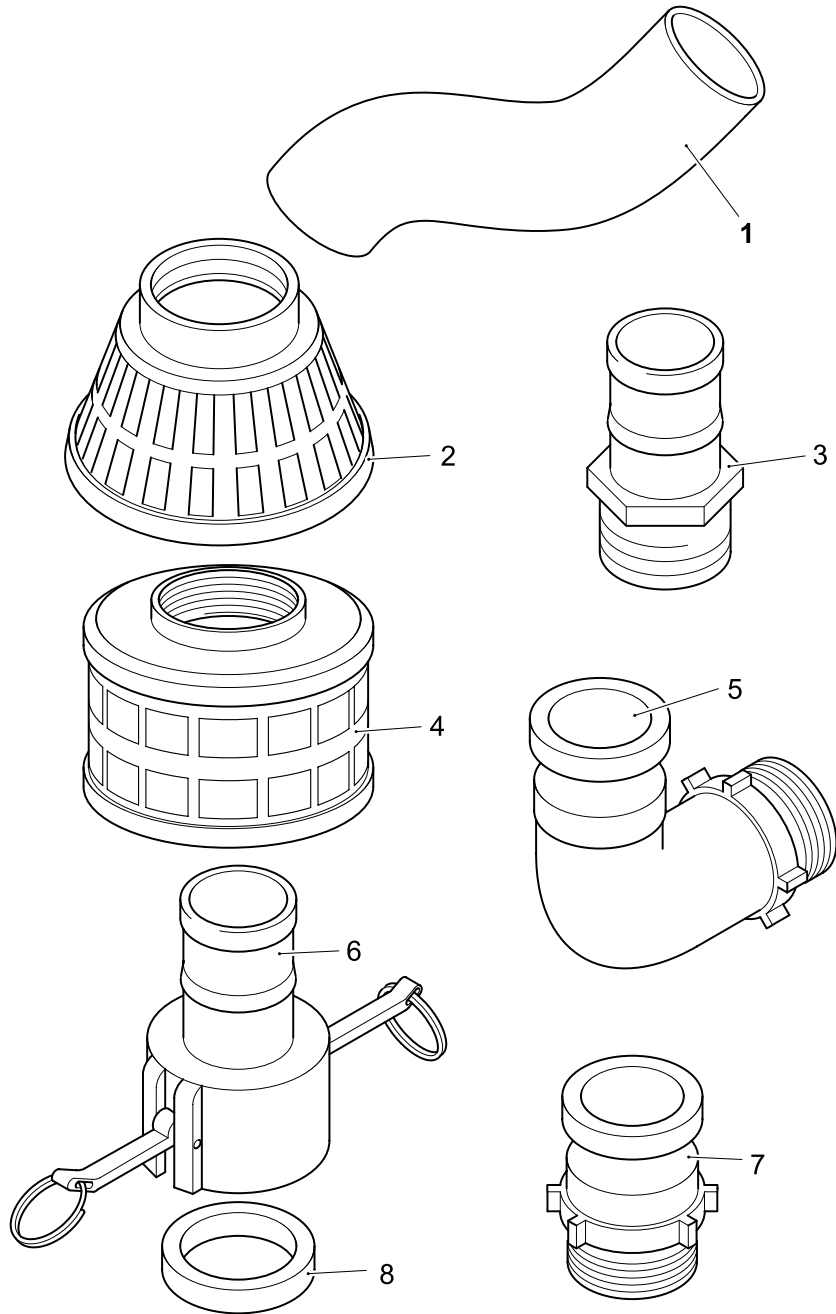

2. Equipment Variants and Options

Special Note

A & S Series Self-Priming Centrifugal Pumps are chemically resistant for general water service, waste treatment, salt water and many industrial chemicals.

Moulded from tough glass reinforced thermoplastics, polyester and or polypropylene to resist corrosion and chemical attack. These pumps feature, as standard, type 316 Stainless Steel internal hardware and carbon-ceramic self-lubricating mechanical shaft seals.

Also available with a choice of seals, o-rings and gaskets made from, Viton, EPDM or Buna-N.

All pumps include a built-in check valve and double flush volute to keep pumps free of settled solids.

All units are fitted as standard with type 304 stainless steel clips and fasteners. Manufactured with a choice of either 2" or 3" port diameters, these pumps handle a wide range of flow and head conditions.

T Series Self-Priming Centrifugal Pumps are lightweight chemically resistant pumps for general service on water, salt water and mildly corrosive liquids containing solids. They will pass a solid up to 1/3 the diameter of the suction port. T Pumps feature a tough non-metallic impeller, steel volute and wear plate with a non-metallic coating, type 316 stainless steel body-clamp, and a housing made from rugged glass reinforced polyester.

The pumps also feature a pressurised oil lubrication system, which protects the hard silicone carbide shaft seal. o-rings and gaskets are made from Buna-N.

All pumps feature a built-in check valve, easy servicing and a self-cleaning double flush volute to keep pumps free of settled solids.

Safety Warning

Verify the chemical compatibility of the liquid you wish to pump with the materials your pump is made from. If you are unsure of the compatibility please contact your local dealer or the service department of Dual Pumps Ltd. Do not use a pump that is chemically incompatible with the liquid you intend to pump. Material failures in pumps caused by chemical incompatibility can cause incidents, which in turn could lead to serious personal injury or even death. Such incidents can also cause serious environmental damage.

This manual deals specifically with the A, S and T type variants of the Dual Pumps Ltd product range.

Power input Petrol and Diesel engines, 4 BHP - 8 BHP.
Electrical drives, 240 – 415 volts.

Pump types Centrifugal 2” inch and 3” inch ports
23 – 36 metres max head.

Transport frame Pumps are housed in rigid steel frames in
either static or wheeled options.

NB: Pumps supplied as bare motor and pump assemblies have no
Transport frame.

Fig 1, Centrifugal Pumps, A, S and T series.

| Model No | Drive | Ports (Inch) | Flow L.p.m | Max Head Metre | Max SG | Weight Kg** | Dimensions LxWxH | *SPL LwA dB | *GSPL LwA dB | Group |
|----------|----------------|--------------|------------|----------------|--------|-------------|------------------|-------------|--------------|-------|
| DPFA200 | Petrol 4 bhp | 2 | 604 | 23 | 1.0 | 19 | 495x345x460 | 101 | 111 | 1-A |
| DPFE3 | Petrol 3.5 bhp | 2 | 604 | 23 | 1.0 | 20 | 576x520x476 | 100 | 111 | 1-Q |
| DPF24P | Petrol 4 bhp | 2 | 568 | 30 | 1.3 | 25 | 576x520x476 | 98 | 111 | 1-B |
| DPF25P | Petrol 5.5 bhp | 2 | 870 | 25 | 1.8 | 25 | 576x520x476 | 107 | 111 | 1-C |
| DPF26P | Petrol 5.5 bhp | 2 | 757 | 36 | 1.2 | 25 | 576x520x476 | 107 | 111 | 1-C |
| DPF35P | Petrol 5.5 bhp | 3 | 984 | 25 | 1.8 | 27 | 576x520x476 | 107 | 111 | 1-C |
| DPF25D | Diesel 6.8 bhp | 2 | 870 | 25 | 1.8 | 50 | 660x445x560 | 109 | 115 | 2-J |
| DPF26D | Diesel 6.8 bhp | 2 | 757 | 36 | 1.2 | 50 | 660x445x560 | 109 | 115 | 2-J |
| DPF35D | Diesel 6.8 bhp | 3 | 984 | 25 | 1.8 | 50 | 660x445x560 | 109 | 115 | 2-J |
| DPF2TP | Petrol 5.5 bhp | 2 | 795 | 27 | - | 39 | 650x445x660 | 107 | 111 | 1-C |
| DPF3TP | Petrol 8 bhp | 3 | 1362 | 24 | - | 65 | 1060x620x650 | 105 | 111 | 1-E |
| DPF2TD | Diesel 6.8 bhp | 2 | 795 | 27 | - | 71 | 1060x620x650 | 109 | 115 | 2-J |
| DPF3TD | Diesel 6.8 bhp | 3 | 1362 | 24 | - | 78 | 1060x620x650 | 109 | 115 | 2-J |

*SPL = Sound Power Level on equipment representative of this type.

*GSPL = Guaranteed Sound Power Level for this equipment.

Appendix 2. Slurry pump service parts list

| Illustration Number | Part Description | Part Number, 2 inch pump | Part number, 3 inch pump | Quantity required |
|---------------------|--|--------------------------|--------------------------|-------------------|
| 1 | Filler plug, oil lube | 9907-722-30A | 9907-722-30A | 1 |
| 2 | O ring | 765-71 | 765-71 | 2 |
| 3 | Lube retainer | 9907-46294-30 | 9907-46294-30 | 1 |
| 4 | Tube | 9907-46215-71 | 9907-46215-71 | 1 |
| 5 | Filler plug, water | 9907-722-30B | 9907-722-30B | 1 |
| 6 | Pump back plate assembly, (bracket) (Includes items 3 & 4) | 46218-31 | 46218-31B | 1 |
| 7 | O ring | 717-71 | 46303-71 | 4 |
| 8 | Washer (diesel only) | 9919-3005 | 9919-3005 | 4 |
| 9 | Screw, Petrol | 715-10 | 715-10 | 4 |
| | Screw, Diesel | 9919-6001 | 9919-6001 | 4 |
| 10 | Oil lip seal | 46314-11 | 46313-11 | 1 |
| 11 | O ring, shaft seal | 976-71 | 46307-71 | 1 |
| 12 | Mechanical seal set | 46250-11 | 46251-11 | 1 |
| 13 | O ring, Volute | 1203-71 | 46292-71 | 1 |
| 14 | Volute | 46224-80 | 46204-80 | 1 |
| 15 | Impeller shim | 778-12 | 46338-10 | As reqd' |
| 16 | Shaft key | 46339 | 46278 | 1 |
| 17 | Volute screw | 462269 | 462269 | 4 |
| 18 | Impeller | 46229-80 | 46214-80 | 1 |
| 19 | O ring | 46291-71 | 46290-71 | 1 |
| 20 | Washer | 46341 | -- | 1 |
| 21 | Impeller screw | 715-10 | 46309-10 | 1 |
| 22 | Wear Plate | 46225-91 | 46205-91 | 1 |
| 23 | Suction gasket | 46206-71 | 46206-71 | 1 |
| 24 | Check valve retainer screw | 1348-10 | 1348-10 | 2 |
| 25 | Check valve retainer | 46344-30 | 46344-30 | 1 |
| 26 | Check valve | 46217-71 | 46217-71 | 1 |
| 27 | O ring, Body | 46304-71 | 46304-71 | 1 |
| 28 | Pump body assembly (Includes items 24, 25 & 26) | 46252-31A | 46207-31B | 1 |
| 29 | O ring drain plug | 1009-71 | 1009-71 | 1 |
| 30 | Drain plug | 723-30 | 723-30 | 1 |
| 31 | Body clamp | 46305-10 | 46305-10 | 1 |

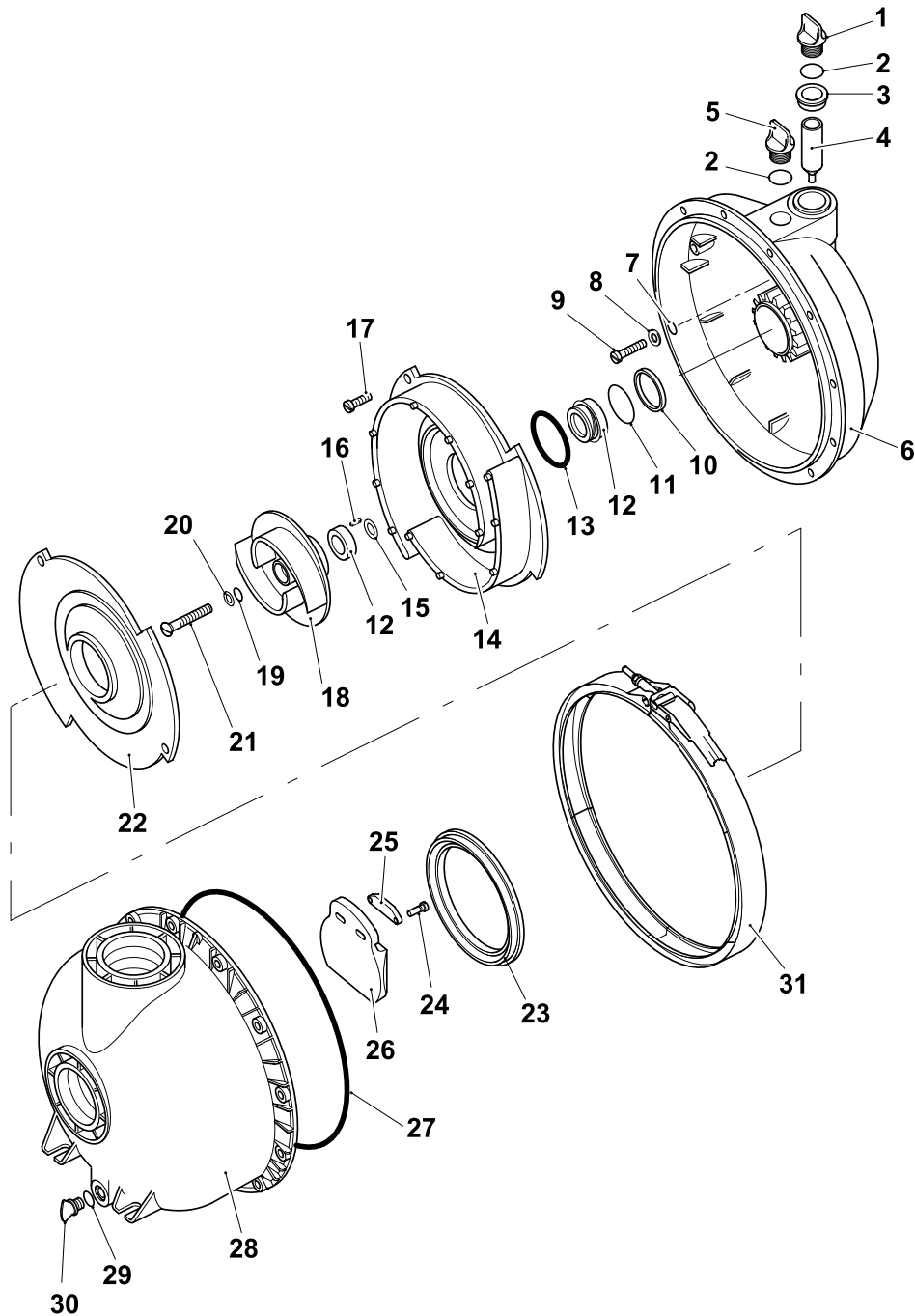

Appendix 2 Slurry pump body assembly (T Series)

Fig 2, Water Pumps, (Bare Pump and Motor Assemblies)

| Part No | Engine Type | Port Size inch | BHP | Max Flow Lpm | Max Pressure bar | Fuel Type | Weight Kg** | Max SG |
|----------|-------------|----------------|-----|--------------|------------------|-----------|-------------|--------|
| 200PDL | Lombardini | 2 | 6.8 | 871 | 2.5 | Diesel | 42 | 1.9 |
| 207PDL | Lombardini | 2 | 6.8 | 757 | 4 | Diesel | 42 | 1.2 |
| 300PDL | Lombardini | 3 | 6.8 | 1060 | 2.5 | Diesel | 44 | 1.8 |
| 200PPV-5 | Honda | 2 | 5.5 | 871 | 2.5 | Petrol | 19 | 1.5 |
| 200PPVDL | Lombardini | 2 | 6.8 | 871 | 2.5 | Diesel | 42 | 1.5 |
| 207P-3 | Honda | 2 | 4 | 568 | 3 | Petrol | 17 | 1.2 |
| 200P-5 | Honda | 2 | 5.5 | 871 | 2.5 | Petrol | 19 | 1.9 |
| 207P-5 | Honda | 2 | 5.5 | 757 | 4 | Petrol | 19 | 1.2 |
| 300P-5 | Honda | 3 | 5.5 | 1060 | 2.5 | Petrol | 20 | 1.8 |

Fig 3, Electrically Driven Water Pumps

| Part No | Volts | Ports inch | BHP | Max Flow Lpm | Max Pressure bar | Weight Kg** | Max SG |
|-----------|-------|------------|-----|--------------|------------------|-------------|--------|
| 207P-ES3 | 240 | 2 | 3 | 504 | 2.4 | 23 | 1.3 |
| 200P-ES3 | 240 | 2 | 3 | 756 | 1.5 | 23 | 1.8 |
| 207P-ET3 | 415 | 2 | 3 | 504 | 2.4 | 23 | 1.3 |
| 200P-ET3 | 415 | 2 | 3 | 756 | 1.5 | 23 | 1.8 |
| 200P-ET5 | 415 | 2 | 5.5 | 756 | 1.5 | 31 | 1.8 |
| 207P-ET5 | 415 | 2 | 5.5 | 725 | 2.5 | 31 | 1.3 |
| 300P-ET5 | 415 | 3 | 5.5 | 880 | 1.5 | 32 | 1.8 |
| 200PP-ET5 | 415 | 2 | 5.5 | 756 | 1.5 | 31 | 1.5 |

** Care should be taken when moving or lifting pump assemblies, they have uneven centres of gravity and may topple when handled.

3.0 General Safety

- 3.1 Centrifugal pump units should only be used by fully trained, competent persons. They should not be used by untrained or inexperienced users. Follow the instructions in this manual and any other supplementary you may be given.
- 3.2 Pump units should never be set in places where they could become a danger to the general public. They should be supervised or securely guarded at all times.
- 3.3 Centrifugal pump units should never be used for pumping incompatible chemicals, flammable or explosive liquids. The pumping of incompatible liquids can lead to fire or explosion, resulting in death or serious injury.

- 3.4 Never operate pump units in a confined space or an explosive atmosphere, the charging and discharging of fuel tanks is forbidden unless the area is well ventilated.
- 3.5 Always site pumps on firm level ground. Vibration caused during the pumping operation may cause the pump to move. Assess any possible danger associated with this and if necessary tether the unit to a solid post.
- 3.6 Never operate any equipment with the guards removed.
- 3.7 Ensure that the pumps drive motor is isolated before working on the pump unit. Petrol and diesel engines should be immobilised so they can- not start. Electric motors should be isolated, by removing fuses. Only competent, authorised persons should be allowed to work on electrical installations. The unit should be declared safe before proceeding with any required service.
- 3.8 Do not apply any heat to a Pump and Motor installation.
- 3.9 The pump body should not be subjected to any internal pressure greater than 4.5 bar, (65 psi). Over pressurisation may be caused by pump shaft speeds of more than 3600 rpm, the quick closing of discharge valves, running over discharge hoses, flooded suctions with a high positive pressure, or the pumping of liquids with a specific gravity, (SG) greater than recommended. (see figs 1,2 and 3).
- 3.10 Protective clothing. Operators and assistants should assess the local hazards associated with the liquid being pumped. The recommended protective clothing as prescribed by COSHH and any other method of hazard analysis should be worn at all times during the installation, pumping and servicing operations.

| Illustration Number | Description | Part Number | Quantity Required |
|---------------------|--|---------------|-------------------|
| 16 | Check valve, Buna * | 9907-705-71 | 1 |
| | Check valve, EPDM * | 9907-705-72 | 1 |
| | Check valve, Viton ** | 9907-705-73 | 1 |
| 17 | Pump body, 2 inch - Polyester (black) | 9907-1002-30 | 1 |
| | Pump body, 2 inch BSP - Polyester (black) | 9907-784-30 | 1 |
| | Pump body, 2 inch - Polypropylene (grey) | B9907-1002-40 | 1 |
| | Pump body, 3 inch - Polyester (black) | 9907-755-30 | 1 |
| | Pump body, 3 inch BSP - Polyester (black) | 9907-877-30B | 1 |
| 18 | Drain plug - Polyester (black) | 9907-723-30 | 1 |
| | Drain plug - Polypropylene (grey) | 9907-723-40 | 1 |
| 19 | O ring, Buna * | 9907-1009-71 | 1 |
| | O ring, EPDM * | 9907-1009-72 | 1 |
| | O ring, Viton ** | 9907-1009-73 | 1 |
| 20 | Filler plug - Polyester (black) | 9907-722-30 | 1 |
| | Filler plug - Polypropylene (grey) | B9907-722-40 | 1 |
| 21 | O ring, Buna * | 9907-765-71 | 1 |
| | O ring, EPDM * | 9907-765-72 | 1 |
| | O ring, Viton ** | 9907-765-73 | 1 |
| 22 | Body bolt, Polypropylene pump (black), st/steel. | 9907-720-10 | 10 |
| | Body bolt, Polyester pump (grey), zinc plated. | 9907-720 | 10 |
| 23 | Body nut, stainless steel. | 9907-721-10 | 10 |
| | Body nut, zinc plated. | 9907-721 | 10 |
| | Impeller shim, 0.007" | 9907-788-11 | As Req |
| | Impeller shim, 0.015" | 9907-788-12 | As Req |
| | Impeller shim, 0.030" | 9907-788-13 | As Req |

*Polyester pump (black body) EPDM seals as standard, Buna & Viton options available

** Polypropylene pump (grey body) Viton seals as standard, Buna & EPDM options available

Repair kits

| Part Number | Description | Included components |
|-------------|---------------------------|---|
| 9907-KT001 | Pedestal conversion kit | n/a |
| 9907-KT014 | Complete seal kit - Buna | |
| 9907-KT005 | Complete seal kit - EPDM | 4 - 5 - 6 - 8 - 9 - 11 - 16 - 19 - 20 |
| 9907-KT017 | Complete seal kit - Viton | |
| 9907-KT024 | Pump repair kit - Buna | |
| 9907-KT025 | Pump repair kit - EPDM | 4 - 5 - 6 - 7 - 8 - 11 - 12 - 14 - 15 19 - 21 - 3x shims - slinger ring shaft sleeve - shaft gasket |
| 9907-KT026 | Pump repair kit - Viton | |

Appendix 1. Water pump service parts list.

| Illustration Number | Description | Part Number | Quantity Required |
|---------------------|---|--------------|-------------------|
| 1 | Pump back plate (bracket) - Polyester (black) | 9907-703-30 | 1 |
| | Pump back plate (bracket) - Polypropylene (grey) | 9907-703-40 | 1 |
| 2 | Plug (Viton pumps only) | 58-1750-90 | 4 |
| 3 | Bracket screw, 5/16" x 1.25" stainless steel | 9907-715-10 | 4 |
| | Bracket screw, 5/16" x 1.5", st/steel (pedestal mount) | 9907-728-10 | 4 |
| 4 | O Ring, Buna * | 9907-717-71 | 4 |
| | O ring, EPDM * | 9907-717-72 | 4 |
| | O ring, Viton ** | 9907-717-73 | 4 |
| 5 | O Ring shaft seal, Buna * | 9907-976-71 | 1 |
| | O Ring shaft seal, EPDM * | 9907-976-72 | 1 |
| | O Ring shaft seal, Viton * | 9907-976-73 | 1 |
| 6 | Shaft seal, Buna * | 9907-714-11 | 1 |
| | Shaft seal, EPDM * | 9907-714-12 | 1 |
| | Shaft seal, Viton ** | 9907-714-14 | 1 |
| | (NB: Item 5 is included in the shaft seal kit, item 6). | | |
| 7 | Shaft impeller key, mild steel | 9907-0718-00 | 1 |
| | Shaft impeller key, stainless steel | 9907-0718-10 | 1 |
| 8 | O ring segment, Buna * | 9907-754-71 | 1 |
| | O ring segment, EPDM * | 9907-754-72 | 1 |
| | O ring segment, Viton ** | 9907-754-73 | 1 |
| 9 | O ring body, Buna * | 9907-719-71 | 1 |
| | O ring body, EPDM * | 9907-719-72 | 1 |
| | O ring body, Viton ** | 9907-719-73 | 1 |
| 10 | Impeller (704) - Polyester (black) | 9907-704-30 | 1 |
| | Impeller (706) - Polyester (black) | 9907-706-40 | 1 |
| | Impeller (975) - Polyester (black) | 9907-975-30 | 1 |
| | Impeller (975) - Polypropylene (grey) | 9907-975-40 | 1 |
| 11 | O ring, Buna * | 9907-717-71 | 1 |
| | O ring, EPDM * | 9907-717-72 | 1 |
| | O ring, Viton ** | 9907-717-73 | 1 |
| 12 | Impeller screw, stainless steel. | 9907-716-10 | 1 |
| 13 | Volute - Flat, for 704 & 706 impeller, polyester pump | 9907-702-30 | 1 |
| | Volute - Ribbed, for 975 impeller, polyester pump | 9907-977-30 | 1 |
| | Volute - Ribbed, for 975 impeller, polypropylene pump | 9907-977-60 | 1 |
| 14 | Volute screw, self tapping, stainless steel | 9907-725-10 | 2 |
| 15 | Volute top screw, for 977 volute | 9907-997-10 | 1 |
| | Volute top screw, for 702 volute | 9907-771-10 | 1 |

Fig 4, Description of main features

(The drive engine illustrated in fig 4 is a petrol version, for diesel engines refer to the engine manufacturers handbook) Electric motors refer to wiring diagram in the motor terminal box.

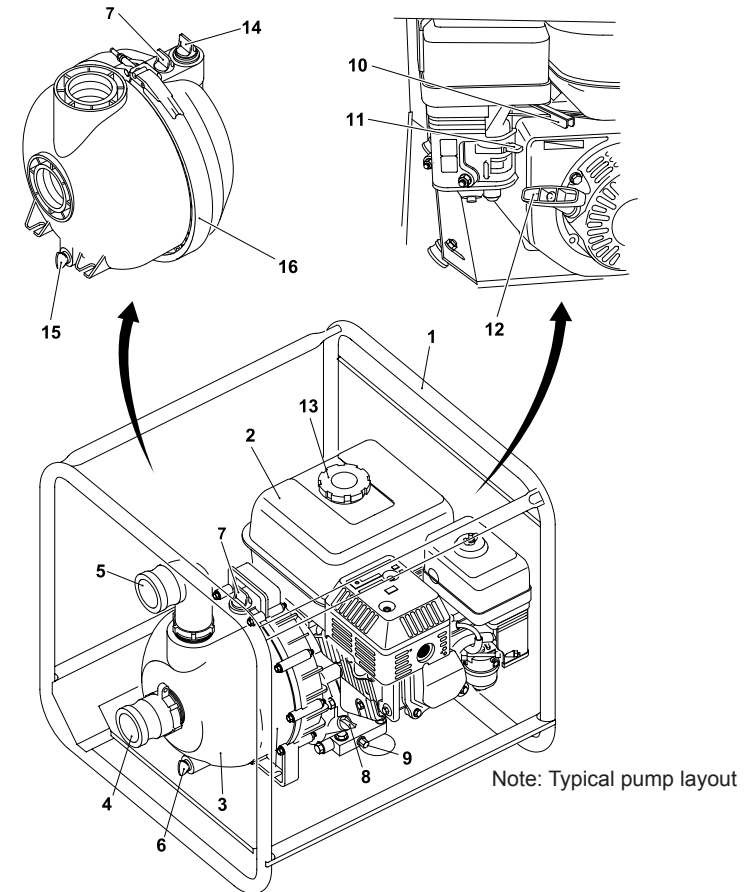

Fig 4 Description of main features

List of main features

- | | |
|--|---|
| 1. Typical transport frame (NB: Wheels are fitted to some models) | 10. Engine speed control |
| 2. Drive engine | 11. Engine cold start |
| 3. Pump assembly | 12. Pull starter |
| 4. Inlet port (suction) | 13. Fuel tank filler |
| 5. Outlet port (pressure) | Slurry pump (see detail drawing) |
| 6. Drain plug | 14. Mechanical seal lubricator |
| 7. Priming port | 15. Drain plug |
| 8. Engine oil dipstick | 16. Removable body clamp |
| 9. Engine oil drain plug | |

5.0 Installation

- 5.1 Fill the engine with the necessary oil and fuel. Refer to engine manufacturers handbook for recommended oils and fuels.
- 5.2 Place the battery in the battery box and connect the power leads. (Electric start models only).
- 5.3 Screw the Inlet and Outlet Quick Release Couplings into their respective ports. Do not over tighten the screw thread. Fittings that are inserted into plastic pump bodies should be hand tight only.
- 5.4 When pumps are installed into permanent situations using solid pipe work use at least 0.3m of flexible pipe on the suction and discharge ports to reduce the possibility of vibration damage.
- 5.5 Long suction and delivery hoses should be supported to reduce possible stress damage to the pump body.

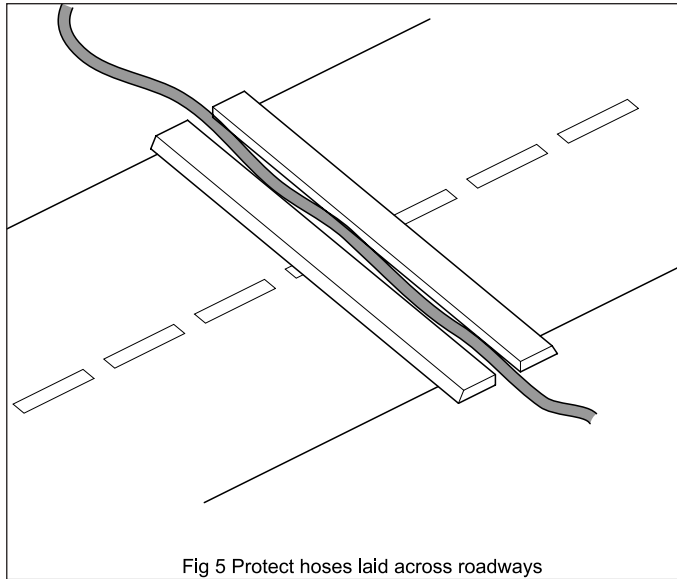
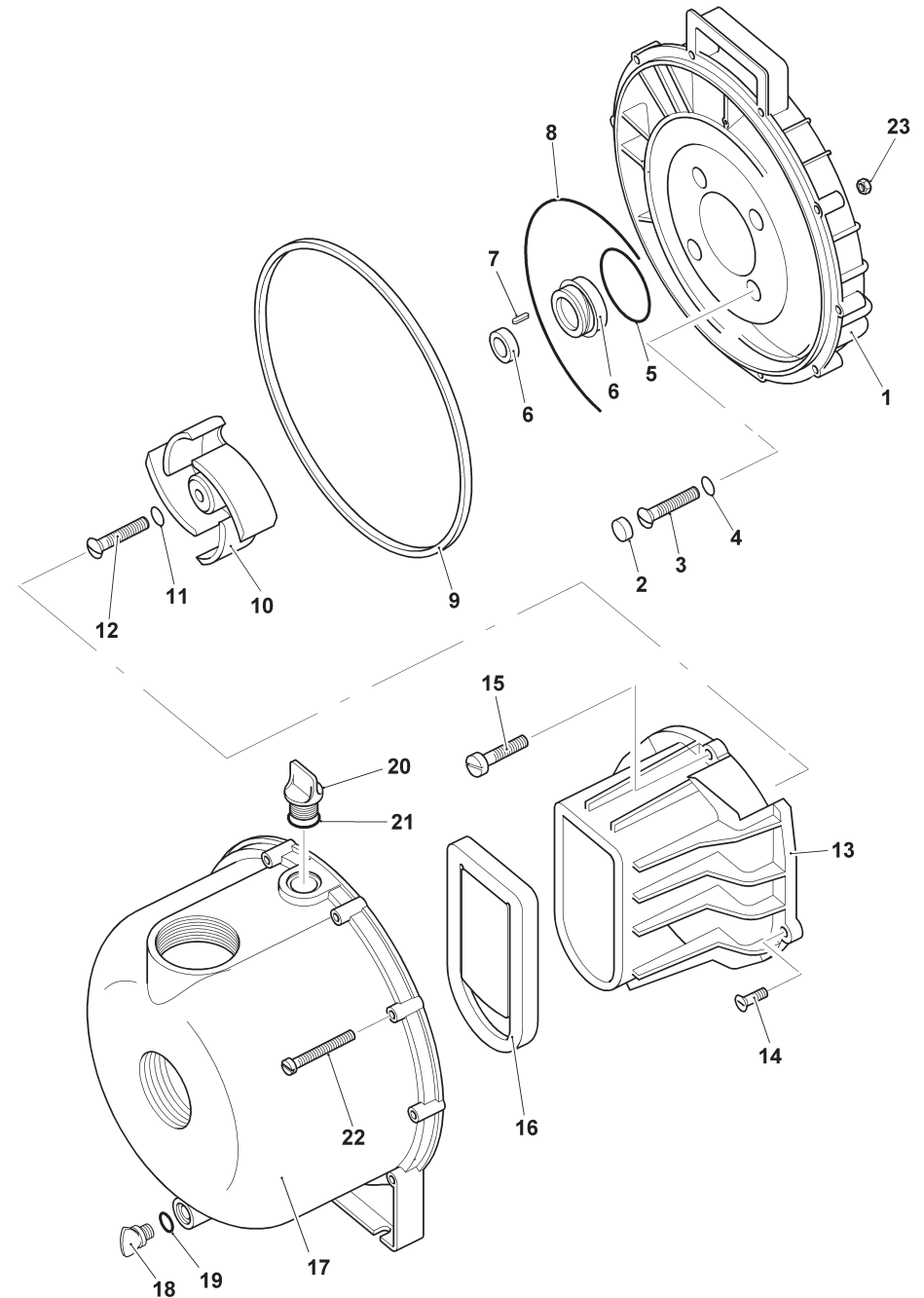

Fig 5 Protect hoses laid across roadways

- 5.6 If flexible hoses are to be laid across roadways ensure they are protected by ramps, planks etc. (see fig 5). Vehicles running across hoses not only damage the hose but also will send shock waves into the pump body, causing mechanical damage or over pressurisation.
- 5.7 Electrically driven pumps should only be installed by a qualified Electrical Engineer. Electric motors refer to the wiring diagram in the motor terminal box. (Ensure the motor is wired for anti-clockwise rotation as you look at the pump impeller or inlet port).



Appendix 1 Water pump body assembly (S Series)

This warranty does not affect any statutory rights that you may have.

Procedure for claiming under this warranty

The claimant must despatch the unit, product or part at his own expense to the Dual Pumps Ltd factory with a full detailed report for inspection, upon receipt Dual Pumps Ltd will inspect and decide whether the unit, product or part is in fact a genuine warranty claim. Upon this decision the pump, product or part will be replaced either free of charge under this warranty or despatched and charged to the original customer together with a full report should it be found not to be covered by this warranty.

Warranty claimed items, if required urgently will be despatched to the customer and charged for, on the receipt of the claimed defective item Dual Pumps Ltd will decide whether a claim is valid and if so will issue a credit for the item. Should Dual Pumps Ltd find the claimed item to be out of warranty declarations the said charge will stand and be paid for by the customer as normal.

The copyright of this manual belongs to Dual Pumps Ltd and must not be copied or reproduced without the express permission of the company.

6.0 Operation

6.1 Preparing to pump

- 6.1.1 Please ensure that the pump you have selected is suitable for the purpose for which it is to be used. Check the maximum head/operating pressure of the pump selected and the liquid type against a suitable table of specific gravities. If you have any doubts about the suitability of the pump for the liquid to be pumped please seek further advice.

WARNING

DO NOT PUMP FLAMMABLE OR EXPLOSIVE LIQUIDS.

- 6.1.2 Check the oil levels on the engine and that the shaft seal lubrication system is filled with oil. (T series, slurry pumps only).
- 6.1.3 Before starting the pump drive fill the pump body with clean water. Avoid running a dry pump for prolonged periods. Dry seals will fail and the pump will then leak.
- 6.1.4 Make sure that all of the hose connections are airtight. Air ingress on the suction port/hose will make the pump difficult to prime and will reduce the pumping efficiency.
- 6.1.5 Always locate the pump as close as possible to the liquid being pumped, this will keep the suction hose as short as possible. Short hoses will improve the efficiency of the pump. Ensure that the ground under the pump is firm and level and that the pump cannot move during the pumping operation.
- 6.1.6 When sucking liquid from a ditch or a pit always use a Suction Filter. Tie the filter so it does not touch the muddy bottom, or place the filter on a pile of large clean stones, (fig 6). Alternatively it can be tied inside a large clean bucket, (fig 7). Both methods will protect the pump from unnecessary damage due to the ingress of stones etc.

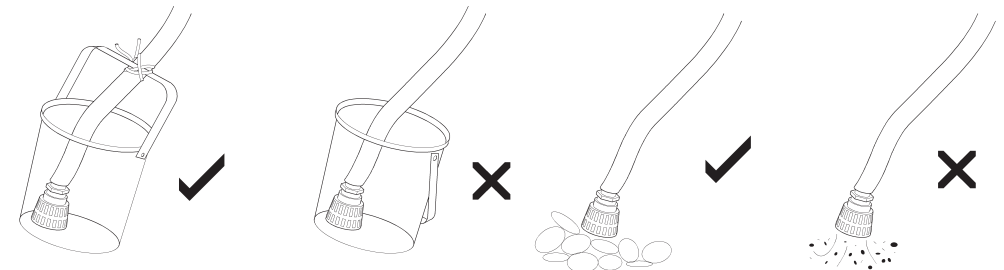

Fig 7 Protecting the suction filter from unnecessary debris

Fig 6 Protecting the suction filter from unnecessary debris

6.2 Pumping

- 6.2.1 Start the drive motor. Refer to the accompanying literature, which relates to the specific type of drive motor fitted.
- 6.2.2 Open all suction and delivery valves. The unit should now be pumping as required. If you experience any problem in the pumping operation refer to section 8, Fault Finding.

6.3 General

- 6.3.1 Do not run the pump for prolonged periods with the delivery line closed or restricted, this will cause the pumped liquid to overheat damaging the pump and in extreme cases explosion.
- 6.3.2 After use, drain and clean (internally and externally) the pump body and the attaching hoses. In frosty weather additional protection should be given to the pump and its hoses to protect them from frost damage.

7.0 Maintenance

7.1 Routine maintenance

| Maintenance activity | Frequency |
|--|---|
| Inspect / top up oil levels a) Engine b) Pump seal lubricator (T series only) | Each and every use. |
| Clean water inlet and suction line filters | Each and every use. |
| Inspect the suction and pressure hoses and their respective connections for damage and air tightness. | Each and every use. |
| Pneumatic tyres, where fitted. Check for wear, damage and abrasion. Check tyre pressures inflate to 0.7 bar, (10 PSI). | Check weekly |
| Change engine oil, only replace the oil with one recommended by the manufacturer. See supplementary literature. | Change as recommended by the engines manufacturer |

7.2 Replacing pump seals, water pump (S series & A series)

(NB: Refer to the illustrations in appendix 1 & 4 to assist with re-assembly).

- 7.2.1 Ensure that the pump body is washed out and drained.
- 7.2.2 Unscrew and remove the body screws (22) S Series (20) A Series and split the pump body by pulling the pump body forwards.
- 7.2.3 Next remove the volute by unscrewing and removing the self-tapping screws (14, 15) S Series (16) A Series.

Neither this warranty or any implied warranty apply to damage caused by any of the following:

1. Freight damage.
2. Frost or freezing damage.
3. Damage caused by parts and/or accessories or components not obtained from or approved by Dual Pumps Ltd.
4. Any consequential or incidental damage arising from the use of any pump or other products supplied by Dual Pumps Ltd.
5. Damage caused by misapplication and/or misuse. The normal wear of moving parts or components affected by moving parts.

The liability of Dual Pumps Ltd under the foregoing warranty is limited to the repair or replacement at Dual Pumps Ltd option without charge for labour, mileage costs or materials of any parts upon return of the entire pump or other product or of the particular part to the Dual Pumps Ltd factory within the warranty period at the sole expense of the purchaser, which part shall upon examination appear to Dual Pumps Ltd satisfaction to have been defective in material or workmanship.

The liability of Dual Pumps Ltd under any theory or recovery (except any express warranty where the remedy is set forth in the above paragraph) for loss, harm or damage, shall be limited to the lesser of the actual cost, harm or damage, or the purchase price of the involved pump or other product when sold by Dual Pumps Ltd to its customers. Dual Pumps Ltd expressly warrants its pumps and other products as above stated. There are no other express warranties. Any implied warranties, including implied warranty of merchantability or of fitness for a particular purpose, are limited to twelve (12) months from the date of purchase by the original purchaser, (six (6) months for the equipment on hire or rental). There is no implied warranty of fitness for a particular purpose or merchantability when this product is put to rental use.

No person including any dealer or representative of Dual Pumps Ltd is authorised to make any representations or warranty concerning Dual Pumps Ltd products on behalf of Dual Pumps Ltd, or to assume for Dual Pumps Ltd the obligations contained in this warranty. Dual Pumps Ltd reserves the right to make changes in design and other changes and improvements upon its products without imposing and obligations on itself to install the same, in its existing products or products then in the process of manufacture.

9.0 After use storage

- 9.1 Disconnect the suction and pressure hoses rinsing clean and allow to dry.
- 9.2 Flush the pump body with clean water, drain by removing the drain plugs. Replace plugs when completely drained. Remove dirt from exterior of pump.
- 9.3 Ensure the pump is clean and dry before storage, store in a dry frost proof place.

10.0 Disposal

- 10.1 At the end of its useful life this pump unit must be disposed of in a responsible manner following any specific requirements of the local authority in which the pump unit is located.
- 10.2 Drain any unused fuel from the fuel tank and the residual engine and lubricating oils. Dispose of these oils in a manner, which is acceptable to your local authority.
Do not dispose of by allowing them to drain into a sewer or watercourse or pollute land.
- 10.3 Remove the plastic components, dispose of by recycling or in general refuse whichever is the locally approved manner.
- 10.4 Metallic parts should be sent for recycling via an approved metal merchant.
- 10.5 Any fitted tyres should be removed from their rims and sent for recycling via an approved contractor.

11.0 Warranty

Dual Pumps Ltd as suppliers warrants to the original purchaser, each new unit or other product supplied from its factory, for a period of twelve (12) months from the date of shipment from the factory, six (6) months for equipment on hire or rental, to be free from defects in material and workmanship under normal use and service. "Normal use and service" means not to exceed recommendations on maximum speeds, pressures and temperatures or handling fluids which are not compatible, as noted in the applicable Dual Pumps Ltd catalogue, technical literature and instructions. This warranty shall not apply to any pump or other product, which has been repaired or altered, to adversely affect the performance or reliability of the pump or product. Tools or hoses are not covered by this warranty due to the adverse conditions of their use.

- 7.2.4 Unscrew the central impeller screw and pull the impeller off of its drive shaft. In some older installations it may not be possible to remove the impeller without damaging it.
- 7.2.5 Remove the bracket screws (3) S Series (7) A Series. In grey polypropylene pumps these are covered by plastic sealing plugs, which will require drilling out.
- 7.2.6 Remove the pump backing plate and gently drift out the old static seal. Take care not to damage the backing plate or when the new seal is fitted a leak free installation may not be possible and a new backing plate may be required.
- 7.2.7 Refit the new static seal. Ensure the o-ring is fitted onto the steel cup. Use a hollow drift (a socket is suitable) that goes over the ceramic face and rests on the steel lip.
- 7.2.8 Assemble the rotating part of the seal into the back of the impeller. Press the seal in gently by hand, do not use excessive force or any tool, which could cause damage. Check that the face of the seal is smooth, should it have a recess remove the rubber boot and reverse the seal. Do not fit a seal that shows any sign of damage. Damaged seals will leak.
- 7.2.9 Reassemble the pump by following steps 7.2.6 to 7.2.2 in reverse order. Do not forget to insert the drive key.

Useful hints and points to note;

Strip the pump completely before ordering any new parts, replace any damaged parts along with worn.
You are advised to always replace the o-ring on the impeller and the screws holding the pump backing plate together with the plastic sealing caps. Use Loctite or a similar product on the pump backing plate screws and the impeller screw.

7.3 Replacing pump seals, slurry pump (T series)

(Refer to the illustration in appendix 2 to assist with re-assembly).

- 7.3.1 Ensure that, the pump body is washed out and then drained.
- 7.3.2 Remove the quick release metal strap holding the two parts of the pump body. Draw the loosened pump body towards you away from the pump backing plate.
- 7.3.3 Remove the large o-ring.
- 7.3.4 Remove the black wear plate. This will expose the volute and the impeller.

- 7.3.5 Remove the impeller by unscrewing the central screw. Inserting a M10 bolt into the central hole. Turn the screw clockwise to draw the impeller off the drive shaft.
- 7.3.6 Remove the volute by unscrewing 2 x M6 screws (4 screws in 3 inch pump).
- 7.3.7 Undo and remove the four screws holding the pump backing plate. Pull the plate forwards over the drive shaft. Remove the drive key first.
- 7.3.8 Remove the static seal and the o-ring from the backing plate and the rotating seal from the back of the impeller.
- 7.3.9 On re-assembly repeat steps 7.3.8 to 7.3.2 in reverse order.
- 7.3.10 Take care not to damage the faces of the seal kit and the oil seal upon reassembly.
- 7.3.11 Shim the impeller until the back of the impeller and the front of the volute are just clear. The shims are inserted into the back of the impeller.
- 7.3.12 The wear plate is assembled onto the lugs on the front of the volute with the indicator arrows pointing upwards. Check for free movement of the pump by turning the pump by hand.

Useful hints and points to note;

Strip the pump completely before ordering any new parts, replace any damaged parts along with the worn.

You are advised to always replace the o-ring on the impeller and the screws holding the pump backing.

Use Loctite or a similar product on the pump backing plate screws and the impeller screw.

8.0. Fault Finding

| Symptom | Probable causes?. | Corrective actions |
|---|--|--|
| Pump will not prime or retain prime after operation. | Air leak in suction line. Clogged valve or strainer | Replace or repair Clean or replace |
| Flow rate is low | Incorrect speed Inlet / outlet pipes are clogged or damaged Clogged or worn impeller Outlet pipe is restricted or undersized High pressure in the outlet pipe. | Check drive speed Clean or replace Clean or replace Flush out piping and or replace Check and reduce pressure pipe. |
| Pump runs but there is no fluid | Faulty suction pipe Pump is located too far from the liquid being pumped Inlet / outlet valves closed Clogged inlet strainer Valves clogged Discharge height is too great Suction lift is too great. | Replace Relocate Clean or replace Clean or replace Clean or replace Reduce the height Lower the pump |
| Liquid drips from the point where the drive shaft enters the pump backing plate, when the pump is full of liquid. | Damaged seal assembly | Replace seals see section 7 |
| The pump starts and stops pumping. | Fouled impeller Faulty mechanical seal Leak in the suction hose Leak in the suction valve Leak in the suction connection | Clean Replace seals see section 7 Repair or replace Repair or replace Repair or replace |
| Excessive noise while the pump is in operation. | Pump not secured to firm foundation Piping not supported to relieve any strain on the pump assembly Restricted suction line Cavitation. | Secure properly Support piping Clean and or replace A Reduce pump speed B Increase the size of the inlet C Viscosity of pumped material too high. |